

# Experimental Method and Characterization of Friction Properties between Woven Fabric and Human Skin in Wet Condition

Xu Wang<sup>a,\*</sup>, Fumei Wang<sup>b</sup>

<sup>a</sup>*Department of Fashion Design and Engineering, Henan Institute of Engineering  
Zhengzhou 450007, China*

<sup>b</sup>*College of Textiles, Donghua University, Shanghai 201620, China*

---

## Abstract

In order to measure the friction force between woven fabric and skin at a wet condition, it was proposed that the completed wetting woven fabric could be hung on the line for different times to reach the different wet conditions. According to the water loss characteristic of woven fabric, the relative hanging time was used to describe the different wetting rates. The friction curves between 20 kinds of woven fabric and human skin were measured by the independently developed fabric-skin friction tester at 6 kinds of wet conditions. It was found that there were 4 kinds of friction-sliding displacement curves. They were normal friction curve, arched friction curve, rising friction curve and decline friction curve. According to the characteristic of various friction curves, 7 kinds of friction indices were defined to characterize the friction properties between woven fabric and skin at wet conditions. They were static friction, turning point between static friction and dynamic friction, average dynamic friction and its coefficient of mean deviation, maximum dynamic friction force, variation rate of dynamic friction and friction coefficient. Besides, it was also found that normal friction curve and rising friction curve usually occurred and their appearing probabilities were 44% and 47%, respectively.

*Keywords:* Woven Fabric; Human Skin; Friction; Testing Method; Wet Condition; Hanging Time

---

## 1 Introduction

There is a lot of water in the human body. It urgently needs heat dissipation and begins perspiring when the external environment temperature rises or the body activity level increases. In most cases, perspiration often stays at the skin surface which will drip or be absorbed by the clothes. Costume will be wet after absorbing perspiration and will stick to the skin surface immediately. During the process of movement, the relative sliding between costume and skin will occur and the friction will be aroused. The wetting fabric which sticks on the skin surface will make the friction sharply increase and seriously influences the skin comfort. Also in daily life, we often

---

\*Corresponding author.

*Email address:* wangxu0086@126.com (Xu Wang).

come across drenched conditions like rain. They belong to wet friction between fabrics and skin as well which makes the human body discomfort to be aroused. In the flood relief, blistering and broken skin caused by wet friction between clothes and skin are common occurrences. Many researchers believed that the adhesion force between fabric and skin surface was the main reason of uncomfortable wear [1-5]. Therefore, it is necessary to investigate the friction property and explore tribological behavior between fabric and skin at wet conditions. It will contribute to developing textile materials, such as sportswear, tight clothes, swimwear and other undergarments. It is also conducive to keep the skin healthy and improve the textile wear comfort.

In this paper, based on the frictional investigation between woven fabric and human skin at normal condition [6], the tribological testing method between woven fabric and skin at wet condition is introduced. The different friction characteristic curves and their distribution regularities between woven fabric and skin are investigated. And then the friction indices (static friction, turning point between static friction and dynamic friction, average dynamic friction and its coefficient of mean deviation, maximum dynamic friction force, variation rate of dynamic friction and friction coefficient) are defined for the follow-up research.

## 2 Experimental

### 2.1 Laboratory Apparatus

The independently developed fabric-skin friction tester was used in this paper [6], as can be seen in Fig. 1. The top end of the fabric was held by the upper clamp. Then the fabric was pulled across the forearm and roller. And the other end of the fabric was held by the lower clamp which exerted uniform initial tension. To ensure a smooth movement, the forearm of the subject under testing was laid on the armrest and was fastened with fixations before testing. Once the testing starts, the forearm would go downward with the friction equipment. The relative sliding friction between fabric and skin would quickly change from static friction state into dynamic friction. At

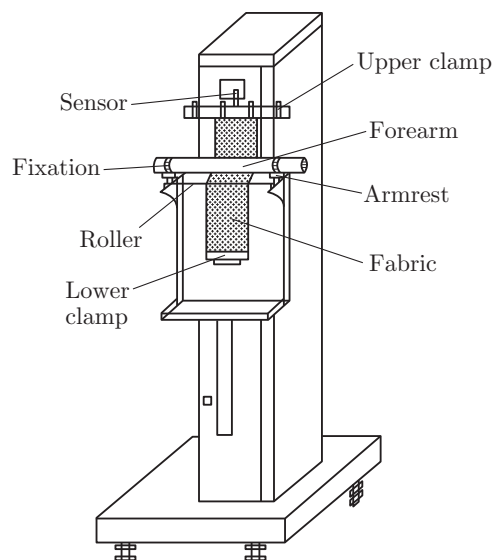

Fig. 1: Schematic diagram of fabric-skin friction tester.